



**ATMO**  
**sphere**  
faster to Europe

---

**natural refrigerants**

---

11-12 October 2011 in Brussels

## LINE-UP NATURAL 5

# FIELD CASE STUDY OF INDUSTRIAL PLANT OPERATING WITH NATURAL REFRIGERANTS

## "Natural Five" Refrigerants and Product Solutions

Refrigerant (Natural Five)	NH <sub>3</sub> R-717	CO <sub>2</sub> R-744	HC Hydrocarbon	H <sub>2</sub> O R-718	Air R-728
90°C		Utility hot water			
60°C	Utility hot water		Utility hot water	Heat recovery	
10°C	Chilled water Ice making	Chilled water Ice making	Heating HVAC	Chiller	
-15°C	Cold storage, Freezer, Fish boat				
-25°C	Specific Refrigeration needs				
-40°C	Freezer, Freeze-dry, Super Low temp storage				
-50°C					
-60°C			Cryogenics		Cryogenics
-100°C					
Notes	<ul style="list-style-type: none"> <li>•Conventional system</li> </ul>	<ul style="list-style-type: none"> <li>•Eco-Cute</li> </ul>	<ul style="list-style-type: none"> <li>•Nat'l Proj.</li> <li>•Butane + Propane</li> </ul>	<ul style="list-style-type: none"> <li>•Nat'l Proj.</li> <li>•Adsorption</li> <li>•Heat recovery</li> </ul>	<ul style="list-style-type: none"> <li>•Nat'l Proj.</li> <li>•Air-cycle</li> </ul>

# CO2/NH3 CASCADE COMPRESSION REFRIGERATION

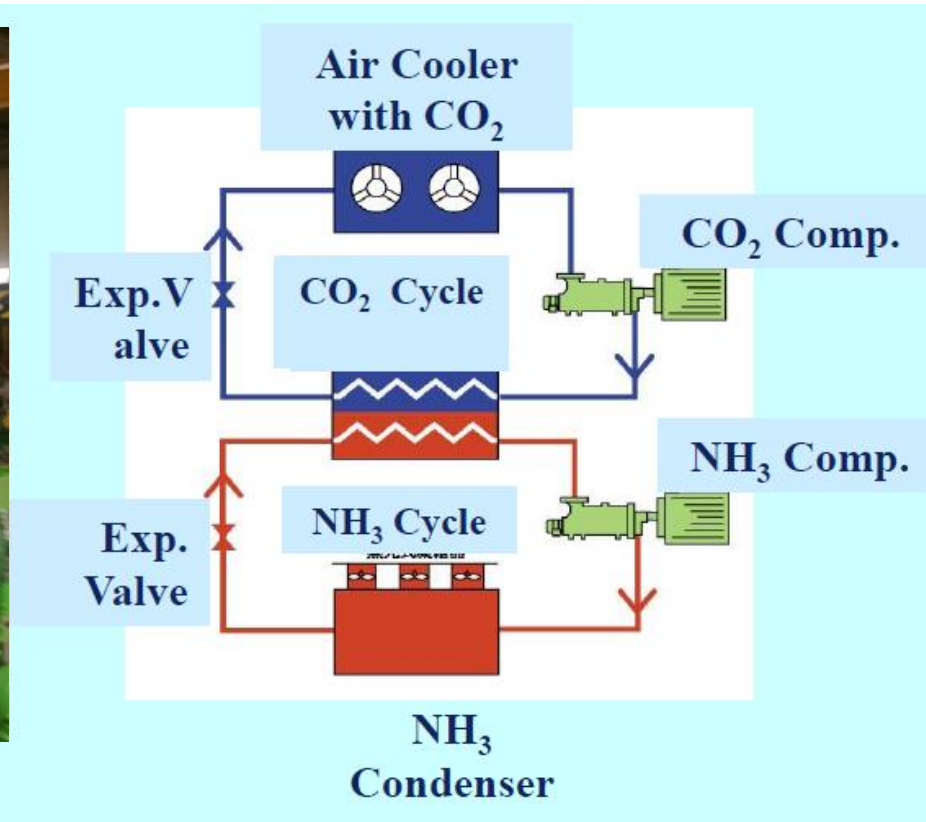

# FIELD CASE

## INTRODUCTION

Starting point, need?

2900kW -51°C

-12°C

-51°C

-35°C

+10°C

+55°C

+35°C

+12->14°C

TC<Twb+10°C

The contractor Cofely Refrigeration bv received the request from his customer to convert & increase the refrigeration size of the plant, in use with refrigerant R22 since 1997, in capacity and freezing temperature from 1300kW at -42°C to 2900kW at -51°C.

The new plant is to be used for processing meat which is frozen during the process, operating 24hrs/day per workweek by using :  
 chilling in the process working rooms requiring -12°C,  
 product freezing :  
 plate freezers(4x550kW), quick freezing tunnel (1x600kW) and a spiral freezer(1x600kW) requiring -51°C,  
 freezing in stores requiring -35°C.

The freezers need to be defrosted by using the CO2 hot gas from the plant.

In addition heat recovery is required to obtain hot water for :  
 the process(55°C),  
 floor-/office-/loaddock-/expedition room heating(35°C),  
 bottom floor freezingrooms (12-14°C),  
 and  
 condensing temperature must not exceed 10°K above wetbulb-temperature (authority requirement)

## ->INTRODUCTION

<p>Why natural refrigerants -51°C</p>	<p>For the temperature of -51°C CO2 is the most suitable refrigerant for direct use on the low temperature system applied in a cascade system with NH3 as refrigerant only used for the high temperature cascade side.</p>
<p>Which choice &amp; why  &lt;2000kg NH3</p>	<p>CO2 for low temperature side used for direct cooling on the freezers. Most suitable NF. NH3 for high temperature side for cascade purpose only as the customer's environmental licence did not allow more than 2000kg NH3 in the plant. NH3 is standard application for Cofely Refrigeration bv.</p>
<p>Timeframe  2003 idea Re-built &amp; Extend 10-2004-&gt;6-2005</p>	<p>In 2003, the idea came up to re-build the plant by re-using the installed compressors and to extend the plant capacity with lower process temperatures by using CO2 as NF.  Plant extension had to be executed from October 2004 till June 2005, Starting with the conversion of the F250VLD units into N250VLD for use with NH3 in May 2005.</p>

## ->INTRODUCTION

<p>Steps to get the project running</p>	<p>Plant stop was scheduled from wk35-2004 to wk25-2005.            Plant erection was done in 5 phases.            Phase 1 : modification of R22 plant to NH3 (from wk18 to wk23-2005)            Phase 2 : installation of CO2 equipment (from wk49-2004 to wk10-2005)            Phase 3 : start-up of C5 &amp; C6 (from wk10-2005 to wk14-2005)            Phase 4 : start up of C7 (wk16-2005)            Phase 5 : start-up of C8 &amp; C9 (wk18-2005 to wk20-2005)            Full production from wk25-2005</p>
<p>Funding, partner : other organisation</p>	<p>Yes            NOVEM (ROB-program : reduction-plan other greenhouse gases-Reductieplan Overige Broeikasgassen) 450.000€            Funding in terms of reduction of greenhouse gases (program management is done by Ministry of VROM and execution is in hands of NOVEM in NL)            EIA (Energy investment deduction) 636.000€ (condition : profitable cie-operation)            VAMIL (free writing off)            MIA (environment investment deduction)</p>



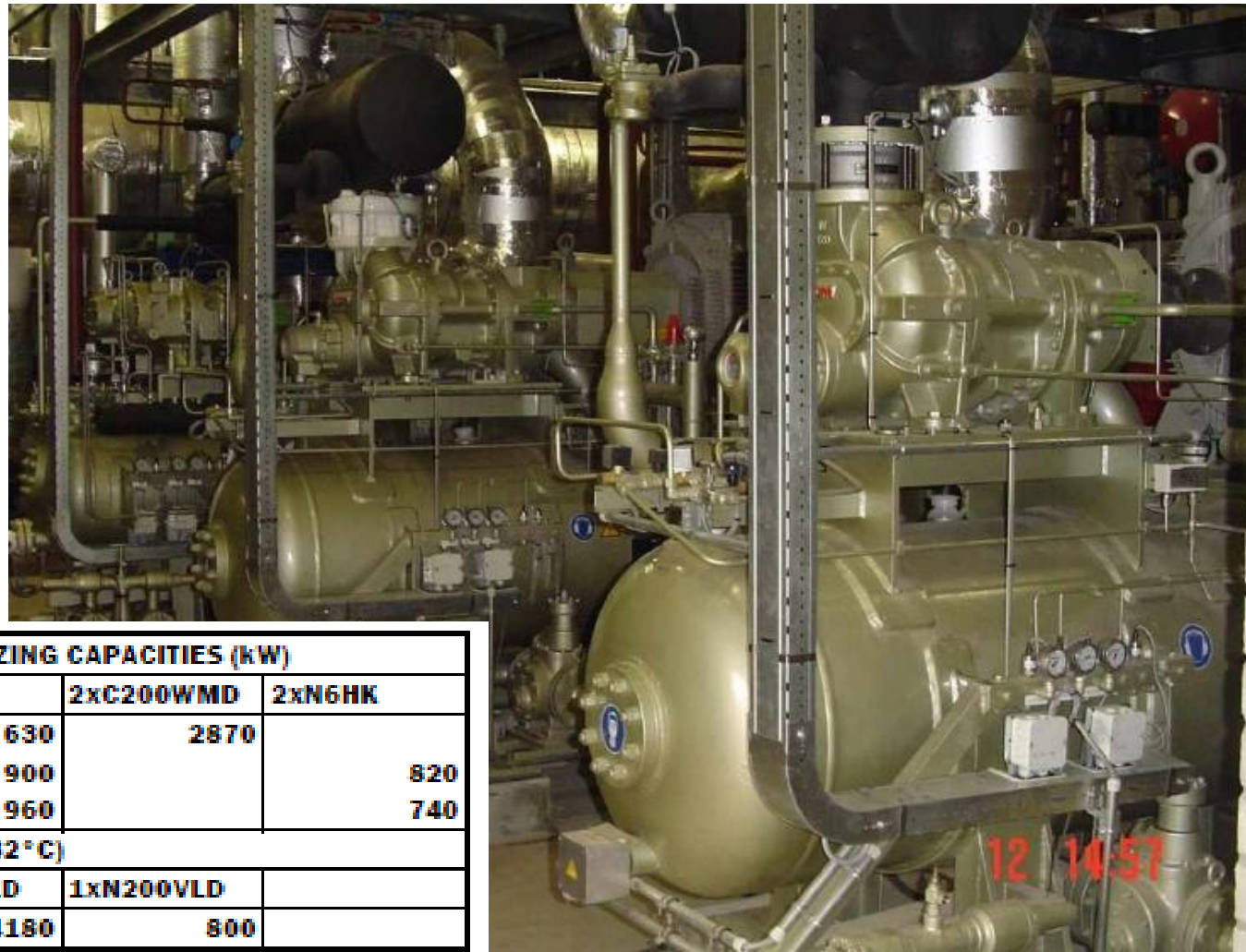

LOW TEMPERATURE SIDE : FREEZING CAPACITIES (kW)			
CO2 LIQUID T° (°C)	1xGH160	2xC200WMD	2xN6HK
-51	630	2870	
-41	900		820
-31	960		740
HIGH TEMPERATURE SIDE (TC = 32°C)			
NH3 TE (°C)	3xN250VLD	1xN200VLD	
-18	4180	800	

COMPRESSOR OPERATING PARAMETERS														TESTS DONE												
CUSTOMER														FILE NAME												
PLANT														SHEET NO												
MYCOM SO NO														ISSUED BY												
UNIT NO														DATE												
COMPRESSOR														REVISION NO												
TC	°C	-13	-12	-11	-10	-9	-8	-7	-6	-5	-4	-3	-2	-1	0	1	2	3	4	5	6	7	8	9		
PD	BARG	23,29	24,01	24,74	25,48	26,24	27,02	27,82	28,63	29,45	30,30	31,16	32,04	32,93	33,85	34,78	35,73	36,70	37,68	38,69	39,72	40,76	41,83	42,91		
TE	PS	PRESSURE DIFFERENCE : DISCHARGE PRESSURE - SUCTION PRESSURE																								
°C	BARG	-31	12,80	10,49	11,21	11,94	12,68	13,44	14,22	15,02	15,83	16,65	17,50	18,36	19,24	20,13	21,05	21,98	22,93	23,90	24,88	25,89	26,92	27,96	29,03	30,11
-32	12,34	10,95	11,67	12,40	13,14	13,90	14,68	15,48	16,29	17,11	17,96	18,82	19,70	20,59	21,51	22,44	23,39	24,36	25,34	26,35	27,38	28,42	29,49	30,57		
-33	11,89	11,40	12,12	12,85	13,59	14,35	15,13	15,93	16,74	17,56	18,41	19,27	20,15	21,04	21,96	22,89	23,84	24,81	25,79	26,80	27,83	28,87	29,94	31,02		
-34	11,45	11,84	12,56	13,29	14,03	14,79	15,57	16,37	17,18	18,00	18,85	19,71	20,59	21,48	22,40	23,33	24,28	25,25	26,23	27,24	28,27	29,31	30,38	31,46		
-35	11,02	12,27	12,99	13,72	14,46	15,22	16,00	16,80	17,61	18,43	19,28	20,14	21,02	21,91	22,83	23,76	24,71	25,68	26,66	27,67	28,70	29,74	30,81	31,89		
-36	10,60	12,69	13,41	14,14	14,88	15,64	16,42	17,22	18,03	18,85	19,70	20,56	21,44	22,33	23,25	24,18	25,13	26,10	27,08	28,09	29,12	30,16	31,23	32,31		
-37	10,20	13,09	13,81	14,54	15,28	16,04	16,82	17,62	18,43	19,25	20,10	20,96	21,84	22,73	23,65	24,58	25,53	26,50	27,48	28,49	29,52	30,56	31,63	32,71		
-38	9,80	13,49	14,21	14,94	15,68	16,44	17,22	18,02	18,83	19,65	20,50	21,36	22,24	23,13	24,05	24,98	25,93	26,90	27,88	28,89	29,92	30,96	32,03	33,11		
-39	9,42	13,87	14,59	15,32	16,06	16,82	17,60	18,40	19,21	20,03	20,88	21,74	22,62	23,51	24,43	25,36	26,31	27,28	28,26	29,27	30,30	31,34	32,41	33,49		
-40	9,04	14,25	14,97	15,70	16,44	17,20	17,98	18,78	19,59	20,41	21,26	22,12	23,00	23,89	24,81	25,74	26,69	27,66	28,64	29,65	30,68	31,72	32,79	33,87		
-41	8,68	14,61	15,33	16,06	16,80	17,56	18,34	19,14	19,95	20,77	21,62	22,48	23,36	24,25	25,17	26,10	27,05	28,02	29,00	30,01	31,04	32,08	33,15	34,23		
-42	8,32	14,97	15,69	16,42	17,16	17,92	18,70	19,50	20,31	21,13	21,98	22,84	23,72	24,61	25,53	26,46	27,41	28,38	29,36	30,37	31,40	32,44	33,51	34,59		
-43	7,98	15,31	16,03	16,76	17,50	18,26	19,04	19,84	20,65	21,47	22,32	23,18	24,06	24,95	25,87	26,80	27,75	28,72	29,70	30,71	31,74	32,78	33,85	34,93		
-44	7,64	15,65	16,37	17,10	17,84	18,60	19,38	20,18	20,99	21,81	22,66	23,52	24,40	25,29	26,21	27,14	28,09	29,06	30,04	31,05	32,08	33,12	34,19	35,27		
-45	7,31	15,98	16,70	17,43	18,17	18,93	19,71	20,51	21,32	22,14	22,99	23,85	24,73	25,62	26,54	27,47	28,42	29,39	30,37	31,38	32,41	33,45	34,52	35,60		
-46	7,00	16,29	17,01	17,74	18,48	19,24	20,02	20,82	21,63	22,45	23,30	24,16	25,04	25,93	26,85	27,78	28,73	29,70	30,68	31,69	32,72	33,76	34,83	35,91		
-47	6,69	16,60	17,32	18,05	18,79	19,55	20,33	21,13	21,94	22,76	23,61	24,47	25,35	26,24	27,16	28,09	29,04	30,01	30,99	32,00	33,03	34,07	35,14	36,22		
-48	6,39	16,90	17,62	18,35	19,09	19,85	20,63	21,43	22,24	23,06	23,91	24,77	25,65	26,54	27,46	28,39	29,34	30,31	31,29	32,30	33,33	34,37	35,44	36,52		
-49	6,10	17,19	17,91	18,64	19,38	20,14	20,92	21,72	22,53	23,35	24,20	25,06	25,94	26,83	27,75	28,68	29,63	30,60	31,58	32,59	33,62	34,66	35,73	36,81		
-50	5,82	17,47	18,19	18,92	19,66	20,42	21,20	22,00	22,81	23,63	24,48	25,34	26,22	27,11	28,03	28,96	29,91	30,88	31,86	32,87	33,90	34,94	36,01	37,09		
-51	5,55	17,77	18,48	19,19	19,93	20,69	21,47	22,27	23,08	23,90	24,75	25,61	26,49	27,38	28,30	29,23	30,18	31,15	32,13	33,14	34,17	35,21	36,28	37,36		
-52	5,28	18,01	18,73	19,46	20,20	20,96	21,74	22,54	23,35	24,17	25,02	25,88	26,76	27,65	28,57	29,50	30,45	31,42	32,40	33,41	34,44	35,48	36,55	37,63		
-53	5,02	18,27	18,99	19,72	20,46	21,22	22,00	22,80	23,61	24,43	25,28	26,14	27,02	27,91	28,83	29,76	30,71	31,68	32,66	33,67	34,70	35,74	36,81	37,89		
-54	4,78	18,51	19,23	19,96	20,70	21,46	22,24	23,04	23,85	24,67	25,52	26,38	27,26	28,15	29,07	30,00	30,95	31,92	32,90	33,91	34,94	35,98	37,05	38,13		
-55	4,54	18,75	19,47	20,20	20,94	21,70	22,48	23,28	24,09	24,91	25,76	26,62	27,50	28,39	29,31	30,24	31,19	32,16	33,14	34,15	35,18	36,22	37,29	38,37		
TC	°C	-13	-12	-11	-10	-9	-8	-7	-6	-5	-4	-3	-2	-1	0	1	2	3	4	5	6	7	8	9		
PD	BARG	23,29	24,01	24,74	25,48	26,24	27,02	27,82	28,63	29,45	30,30	31,16	32,04	32,93	33,85	34,78	35,73	36,70	37,68	38,69	39,72	40,76	41,83	42,91		

## CO2 GH160 TEST 19.4.05 DEFROST CONDITION (pressures in bar(a))

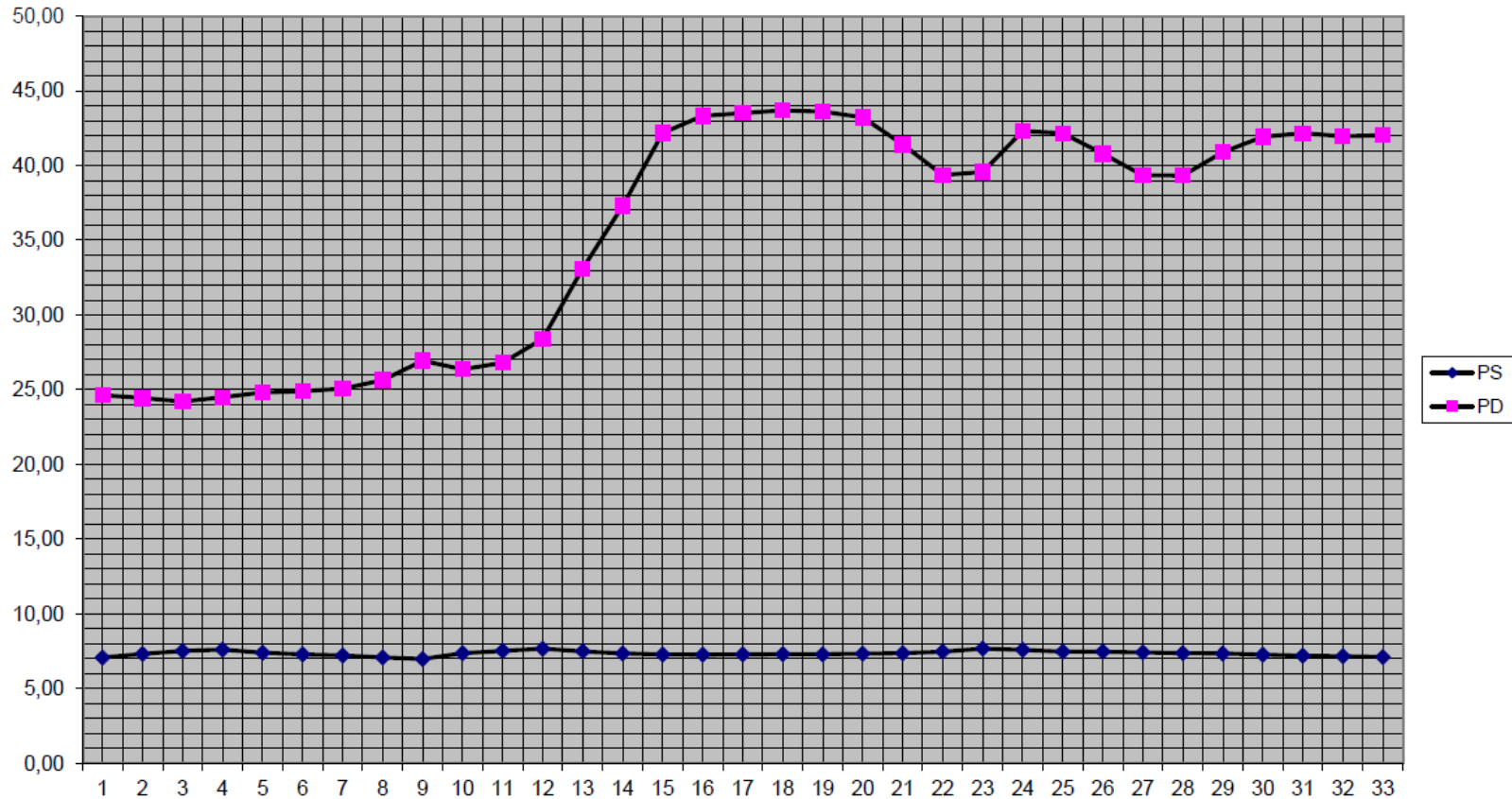

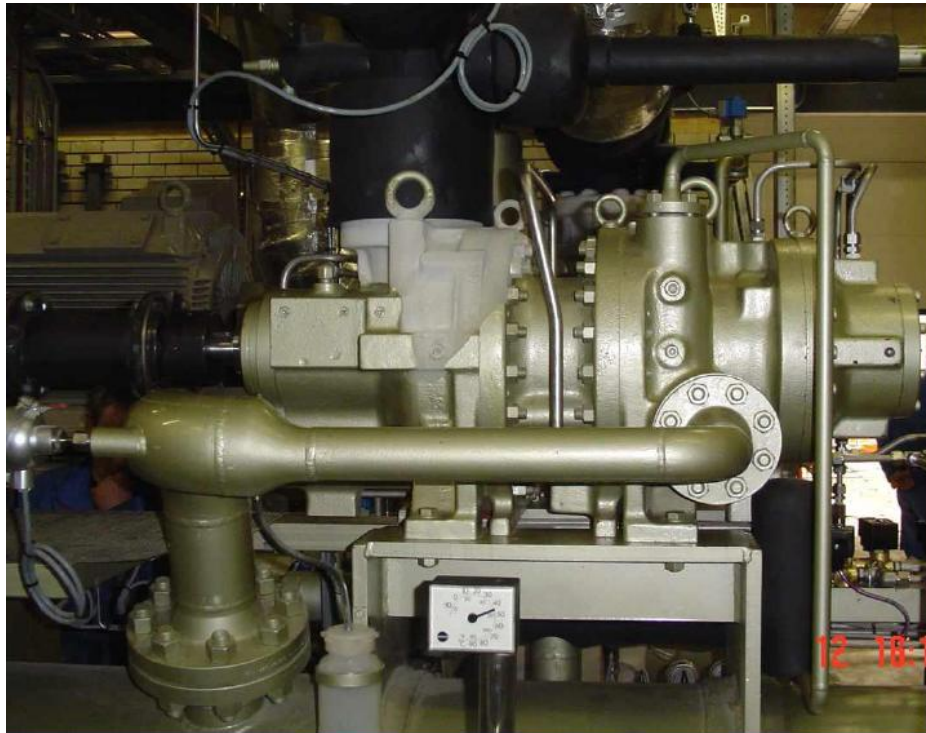

### OVERVIEW INSTALLED COMPRESSORS :

natural	type	unit	date	hours**
CO2	C6HK	C5	2005	49027
CO2	C6HK	C6	2005	2666
CO2	GH160	C7	2005	41144
CO2	G200VMD	C8	2005	30878
CO2	G200VMD	C9	2005	3762
NH3	N250VLD	C1	1997	61301 *
NH3	N250VLD	C2	1997	39812 *
NH3	N250VLD	C3	1997	38133 *
NH3	N200VLD	C4	2005	54928

\* : Incl. F250VLD use 1997->2005

\*\* : 5-10-2011

## EFFICIENCY ANALYSIS

d  
e  
s  
i  
g  
n

CO2/NH3 CASCADE		RT	BKW	THR	COPc-each	COPc-total
TE=-51°C	TC=+32°C	kW	kW	kW		
CO2 LS	GH160	629	184	813	3,4	
	C200VMD	1100	311	1411	3,5	
	C200VMD	1191	330	1521	3,6	
	total	2920	825	3745	3,5	1,61
NH3 HS	N250VLDx2	2760	723			
	N250VLDx1	987	268			
	total	3747	991		3,8	

a  
v  
e  
r  
a  
g  
e

CO2/NH3 CASCADE		RT	BKW	THR	COPc-each	COPc-total
TE=-51°C	TC=+25°C	kW	kW	kW		
CO2 LS	GH160	629	184	813	3,4	
	C200VMD	1100	311	1411	3,5	
	C200VMD	1191	330	1521	3,6	
	total	2920	825	3745	3,5	1,75
NH3 HS	N250VLDx2	2820	626			
	N250VLDx1	927	214			
	total	3747	840		4,5	

## ->EFFICIENCY ANALYSIS

Difference planned & actual results if occurred?	
<p>If yes, why were there differences?</p> <p>TC:32-&gt;25°C 90600€</p>	<p>For the main freezing load of 5 days 24hrs operation :</p> <p>Average condensing temperature on the NH3 cascade compressors is reduced from design value of 32°C to 25°C, this means a compressor absorbed power reduction of 151kWh or 906 MWh based on 6000hrs operation per year. (COP-c increase of 8,7%)</p> <p>This represents an energy saving for the customer of 90600 € (based on 0,10€/kWh)</p> <p>Heat recovery . 690 MW/year (process use)</p>
<p>How is the process of measuring efficiency?</p>	<p>The freezing equipment is operating following load programs which must be covered by the refrigeration plant, which was fulfilled.</p> <p>Per type of compressor 1 machine is equipped with frequency convertor for speed control at part-load operation in order to keep the best COPc</p>

## COST ANALYSIS

COSTS INVOLVED & POSSIBLE COST SAVING OR HIGHER SPENDING FOR THIS PROJECT.	This installation represents for Cofely Refrigeration bv a value of approx. 4.000.000 €.
Estimated price difference to conventional system	The comparison with synthetic refrigerant R507 has been considered. Cofely Refrigeration bv concluded that this solution was much more expensive than the chosen CO2/NH3 concept.

## ->COST ANALYSIS

Savings or potential savings because of existing or pending regulation

At the completion and the acceptance of the new CO<sub>2</sub>/NH<sub>3</sub> plant, TNO reported that the CO<sub>2</sub>/NH<sub>3</sub> plant is significantly more efficient than a comparable plant with R507. The calculated savings amount to 23% on energy, resp. 49% on CO<sub>2</sub> equivalent emission at that time.

In addition the plant is equipped with following energy-saving options :

- heat recovery
- high efficiency electrical motors
- hot gas defrosting
- frequency controllers
- energy-saving condensers



## ->COST ANALYSIS

<p>Potential savings in the future</p> <p>70-80°C hot water</p>	<p>As the process needs hot water at temperature level of 70 to 80°C there is great interest to add hot water overcompression heat pumps with operation during the cheaper night-time power price and to buffer hot water for use during the production process.</p> <p>There is plenty of heat rejected from the high stage NH3 cascade plant (over 4 mW per hour during week-production days) which can be used as heat source for the heat pumps.</p>
<p>Did forecast succeed/expectations were met?</p>	<p><b>The customer is absolutely happy with the plant.</b></p>

## BARRIERS & SOLUTIONS

WHAT BARRIERS WERE WE FACING WITH THIS PROJECT & HOW SOLVED ?	
Technical problems or availability of systems, components, engineers?	As this plant was one of the first in Europe realised, supply and availability of high pressure components has been one of the faced bottle necks. Thanks to the customer who gave full confidence and made strong investment in this new technology to Cofely-GDF Suez it was possible to succeed and realise this plant with success !
Psychological barriers from customer:management?	Not as customer fully relied on the capability Cofely Refrigeration.
Safety problems, legilative barriers?	The plant/system was build fully in compliance with CE-PED.
Short term cost differences?	Not

## LESSONS LEARNED

WHAT HAS BEEN LEARNED FROM THE PROJECT & HOW CAN THIS BE APPLIED TO OTHER PROJECTS USING NR.	
What will you do different in the future?	For the refrigeration plant, the customer will go for the same solution as demonstrated by this field case which is already running 6 years with full satisfaction !
What can you apply to the next project?	With the next plants where hot water is needed in the process, necessary important energy savings should be implemented by installing hot water high pressure compression heat pumps with NF NH3 by recuperating the condensor heat from the cascade NH3 high stages which is available in great quantities.

## FUTURE PLANS

Have you planned or do you know about similar projects?	
What are your recommendations for the planning, design etc. Of NR systems ?	Continue in the same line. The Cofely group has more than 60 CO2 plants in operation which have been installed since 2001!

# ACTION PLAN

<p>IDEAS OF CONCRETE ACTIONS TO GET NATURAL REFRIGERANTS FASTER TO EUROPE :</p>	
<p>1.1. What are the concrete actions already done ?</p>	<p>Mayekawa only promotes natural refrigerants since the beginning of this century.</p>
<p>1.2. Or/and planning to do ?</p>	
<p>2.1. what kind of actions needed to expand NR systems, for :</p> <p>Technology, Training, Safety,</p> <p>Policy, Standards, Regulation,</p> <p>Market, Costs, End-users.</p>	<p>Unlimited development ongoing. With each new product:system necessary trainings are also made available. Suppliers of refrigeration accessories (EN378 qualified) should make more products available for high pressure/big size duty. Mayekawa still have too often to rely on expensive accessories designed for oil and gas industry.</p>

# CONCLUSION

## **NATURAL REFRIGERANTS FASTER TO EUROPE :**

THIS PROVEN FIELD EXAMPLE SHOWS THAT THE SUCCESS OF THE NEW TECHNOLOGY IS MUCH DEPENDING ON THE QUALITY OF THE PREPARATIONS DONE ON BEFOREHAND FOLLOWED BY THE INSTALLATION AND COMMISSIONING WITH OPTIMAL FINE TUNING, FROM COOPERATION BETWEEN ALL PARTIES INVOLVED :

MANUFACTURER : MAYEKAWA JAPAN/  
MAYEKAWA EUROPE  
CONTRACTOR : COFELY REFRIGERATION  
& END-USER.



THANKS FOR YOUR  
ATTENTION!

Thanks to the Contractor of the plant in the fieldcase : COFELY REFRIGERATION bv(NL) Mr.Willy van Leeuwen  
(willy.van.leeuwen@cofely-gdfsuez.nl)

Presented by Jan Boone, MAYEKAWA

# MAYEKAWA MYCOM

## WORLDWIDE

- 33 countries / 119 offices
- 8 production plants



## MAYEKAWA Europe Organization



### SWITZERLAND

Rosenbergstrasse 31,  
CH - 6300, Zug  
Tel. +41 41 726 8626  
Fax +41 41 726 8620  
<http://www.mayekawa.ch/>  
E-mail [info@mayekawa.ch](mailto:info@mayekawa.ch)

### SPAIN

Calle Montevideo 5,  
Nave 13 POL.  
Industrial Campopomosó  
28506 Alcala de Henares, Madrid  
Tel. +34 91 830 0392  
Fax +34 91 830 0397  
<http://www.mayekawa.es/>  
E-mail [mayekawa@mayekawa.es](mailto:mayekawa@mayekawa.es)

### RUSSIA

House 3, Flat 54, Mytnaya  
St. Moscow, 119045  
Tel. +7 499 230 01 76  
Fax +7 499 230 21 12  
<http://www.mayekawa.ru/>  
E-mail [info@mayekawa.ru](mailto:info@mayekawa.ru)

### GERMANY

Gabriele-Münter Strasse 3,  
82110 Germering  
Tel. +49 89 5527 969 0  
Fax +49 89 5527 969 19  
E-mail [info@mayekawa.de](mailto:info@mayekawa.de)

### FRANCE

9, Rue Michael Faraday,  
75150 Montigny-Le-Cretonneux,  
Tel. +33 1 30 58 2600  
Fax +33 1 30 58 1937  
<http://www.mayekawa.fr/>  
E-mail [mycom-france@mayekawa.eu](mailto:mycom-france@mayekawa.eu)

### UNITED KINGDOM

16 Oakhurst Gardens,  
Bexleyheath, Kent DA7 5JP  
Tel. +44 1322 433556  
Fax +44 1322 433164

### BULGARIA

94, Hristo Botev Str.1202 Sofia  
Tel. +359 2 8910130  
Fax +359 2 8910131

### DUBAI

P.O.Box.61349, LOB. 11, No.126,  
Jebel Ali Free Zone, Dubai, U.A.E  
Tel. +971 4 867 2232  
Fax +971 4 867 2238

### INDIA

1st Floor, Balaji House,  
Nr. Mansarovar Heights,  
Mumbai-Puna Road, Pimpri,  
Pune-411 018  
Maharashtra, India  
Tel. +91 20 2748 4537  
Fax +91 20 2748 4539

### AUSTRALIA

Unit 2,44 McCauley  
Street Matraville NSW 2036 Australia  
Tel. +61 2 9695 7000  
Fax +61 2 9695 7001  
E-mail [mycomaus@mayekawa.com.au](mailto:mycomaus@mayekawa.com.au)

### NEW ZEALAND

20 Tui Street Otahuhu P.O. Box 12108  
Auckland New Zealand  
Tel. +64 9 276 2305  
Fax +64 9 276 2306  
E-mail [mycom@ihug.co.nz](mailto:mycom@ihug.co.nz)

### JAPAN HEAD OFFICE

3-14-15 Botan Koto-KU,  
Tokyo 135-8482, JAPAN  
Tel. (81)-3-3642-6161  
Fax (81)-3-3643-7094  
E-mail [e-public@mayekawa.co.jp](mailto:e-public@mayekawa.co.jp)

### MAYEKAWA Europe nv/sa

Leuvensesteenweg 505  
1930 Zaventem - Belgium  
Tel. +32 2 757 90 75  
Fax +32 2 757 90 23  
URL <http://www.mayekawa.eu>  
E-mail [info@mayekawa.eu](mailto:info@mayekawa.eu)

Global web site  
<http://www.mayekawa.com/>