

YOUR *Only at*
M&S

ATMOSphere 2013

October 2013

Paul Alway

How many Stores use CO2 as a refrigerant?:



540 Food Halls, 80 Operating with CO2

Types of Plant we currently have

CO2 Pumped Cascade Systems

- Started with R404a/CO2 Cascade Plant
- Trialled HC/CO2 Cascade Plant in 3 Stores
- Currently we Install R134a/CO2 Cascade Plant



(HC/CO2 in the picture – Stratford City Store)

How does it operate?:

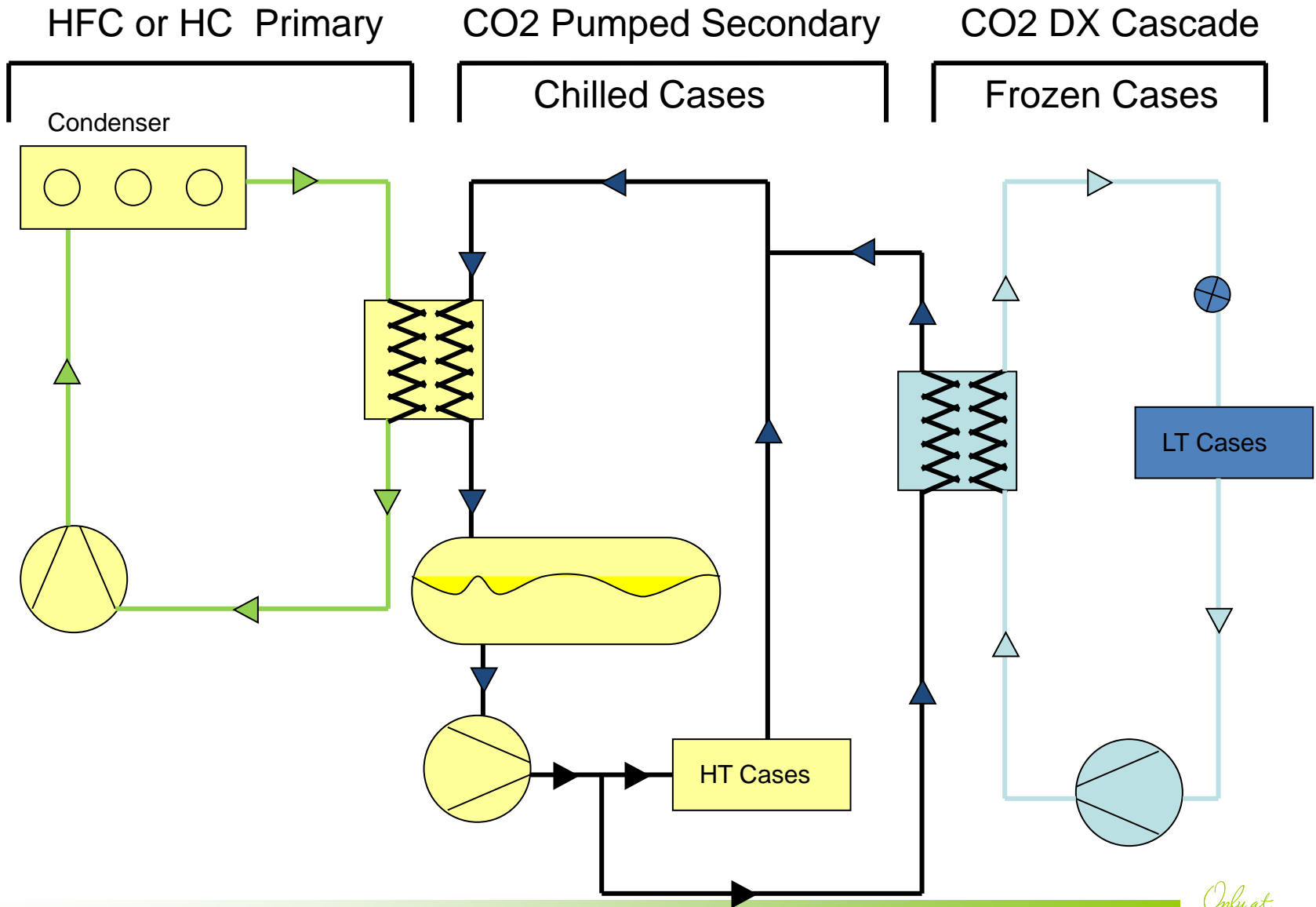

What's it like to live with?

Food Sales are Growing – We sell cold food!!

- Day to day the plant is reliable and Energy Efficient
- Quite a complicated industrial system
- Difficult to diagnose specific problems

General issues experienced:

- Valve settings drifting
- Leaks (Valve and pump seals)
- Cases operating DX or Vapour locking
- Oil trips
- Housings Overheating
- Blocked Filters

Lot of these issues are experienced on traditional HFC systems

What's Next?:

HFC Free

Heat Reclaim

What's Next?:

Transcritical CO₂ ???

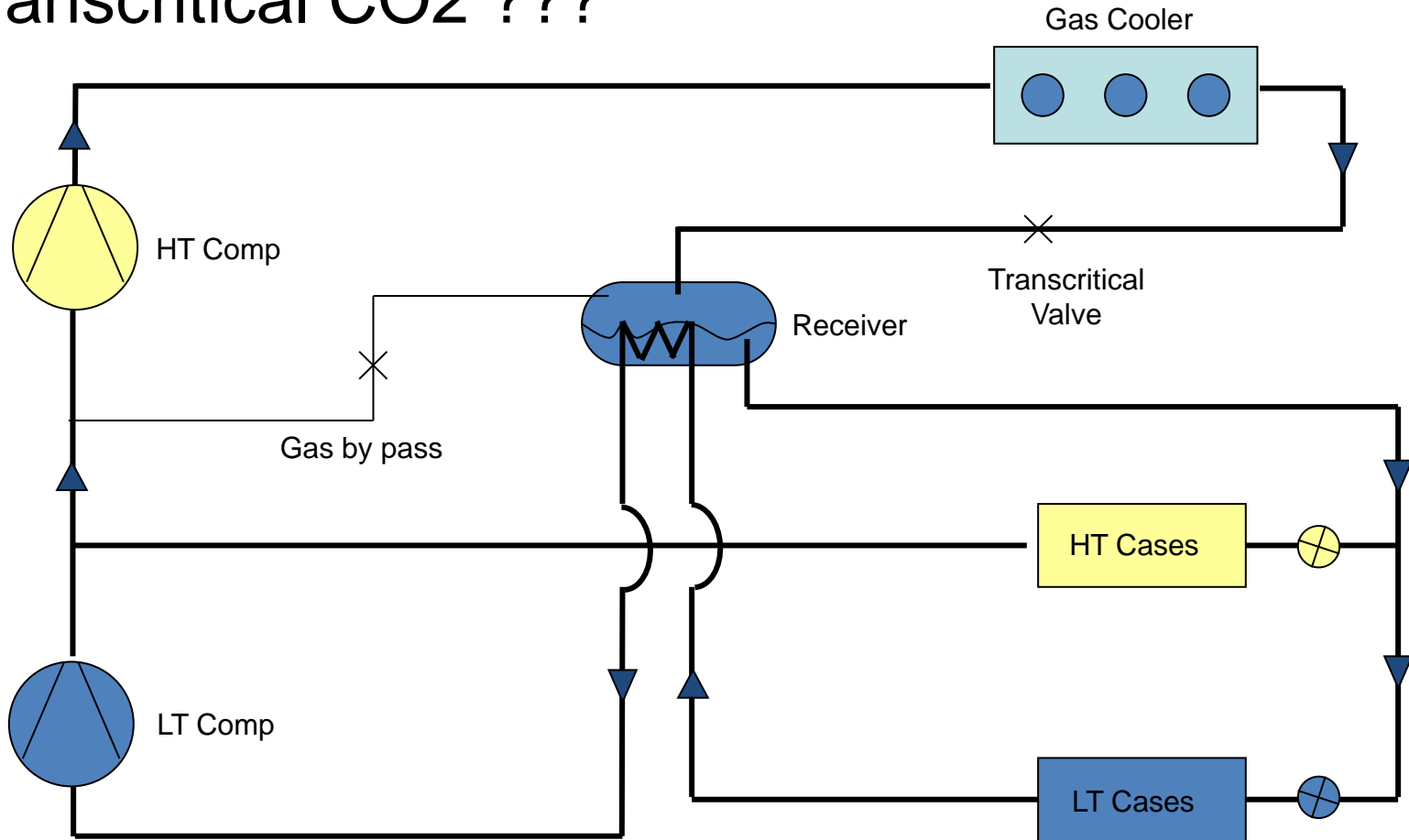

Test and Learn!

- Stop using our shops as test beds
- Learn what we need to know in a controlled environment

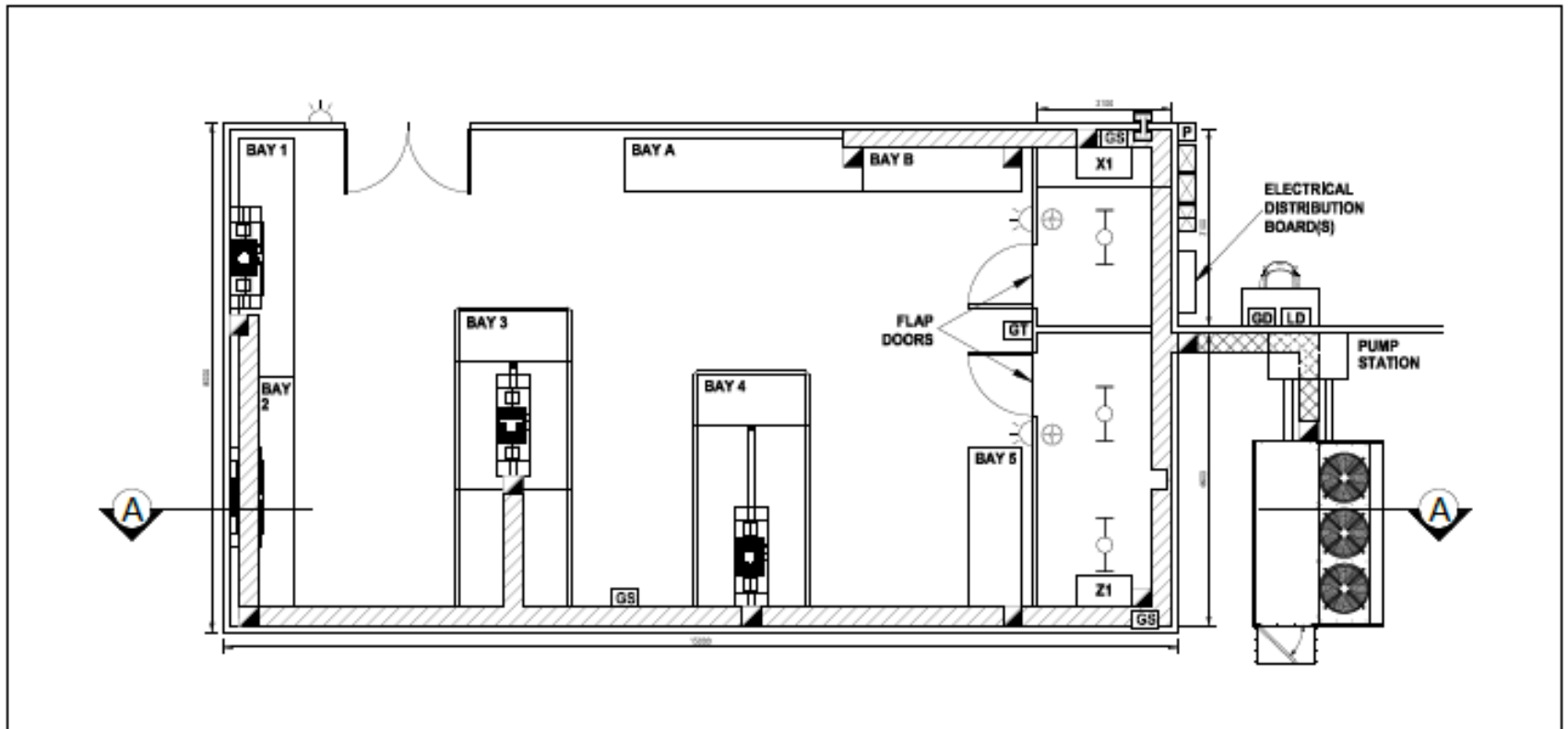

Only at
YOUR M&S