



Metro Group:

- Leading international specialist in wholesale and food retail
- Operates in 35 countries
- With 1000 locations
- Employees more than 150,000 people
- Generated sales in 2016/17 around €37.1 billion
- Sets the standards for tomorrow: for customer focus, digital solutions and sustainable business models.

Metro Cash and Carry:

- Operates in 25 countries
- With 750 Metro Cash and Carry stores
- Employees around 100,000 peoples

CLIMATE PROTECTION TARGET 2030

Climate protection target 2020 already achieved in 2015:

=> Reduction of core CO₂ emissions on METRO Group* level by 20% vs. 2011.



New climate protection target for 2030:

=> Reduction of core CO₂ emissions on METRO Group* level by 50% vs. 2011.

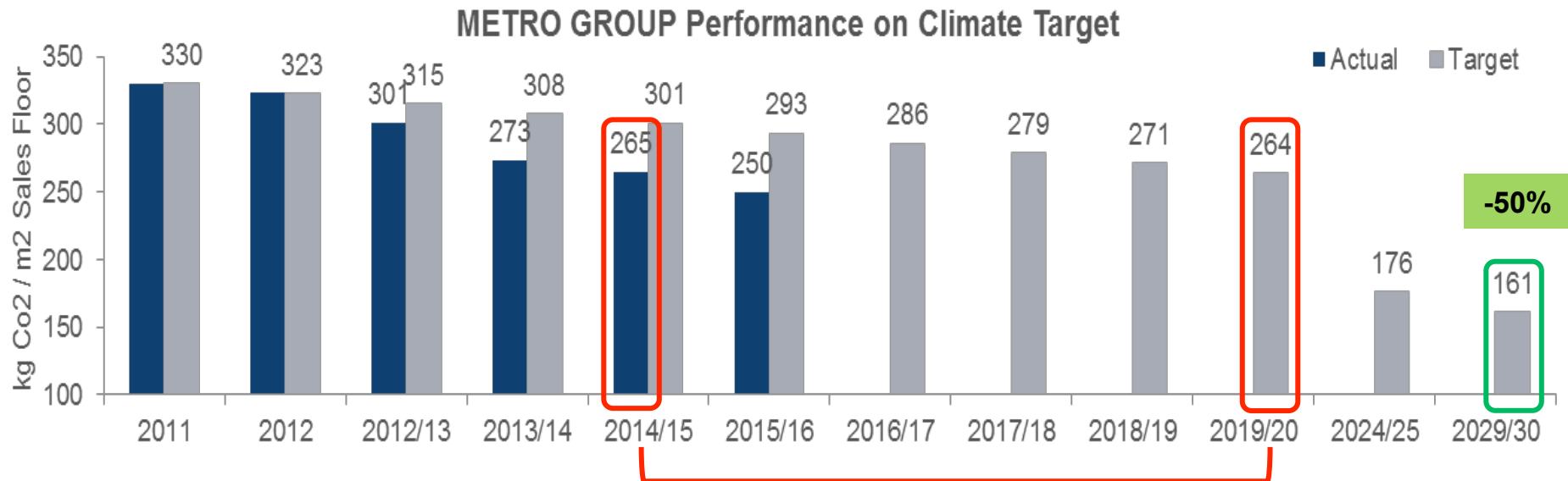

*before demerger

CO2 REDUCTION STRATEGY 2030

To achieve our Climate Protection Target, METRO focuses on four pillars:

(1) Energy-Efficiency Investments (ESP) & Behavior (EAP)

(2) F-Gas Exit Program – FEP

(3) Renewable Energy Production Project

(4) GREENSTORE (China Dongguan and Jinan) + ZEUS INITIATIVE (ZERO Emission Unit Store in St. Polten)



F-GAS EXIT PROGRAM 2030

- In all new store openings + refurbishment stores: **only natural refrigerants!**
 - Life cycle of existing cooling equipment (**CO₂**, Propane, Ammonia)
 - Selction criteria: technical possible; maintenance & repair is secured; refrigerant GWP <2500;
 - Realization + executionJ: until 2030
 - Benchmark leakage rate: taylor made solutions for existing equipment in proper technical condition
 - Full contribution of the refrigeration resolution: Oct 2016 from „CGF“

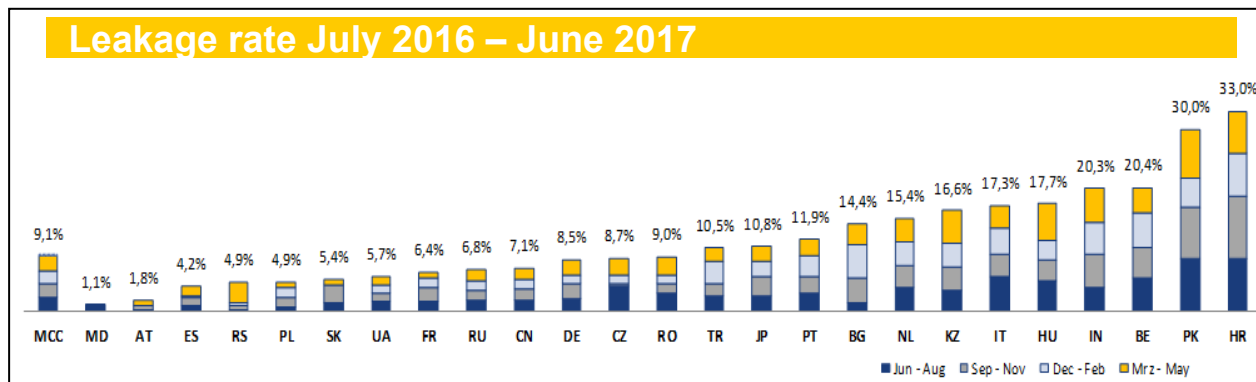

F-GAS EXIT PROGRAM STATUS

- METRO Cash & Carry:
 - > 140 Stores with CO2 in METRO Cash & Carry:
 - > 60 transcritical Systems (e.g. NL/FR/BE/PL/IT/AT/DE)
 - > 70 subcritical Systems (e.g. CN/RU/HR/UA/TR/PT/SK)
 - 1 HFO (CZ)

- Closed furniture:
 - Closed cooling shelves, doors & cabinets;
 - Minus system: done
 - Plus system: >50% (HU/CZ/BE/+ starting in CN/RU/UA)

- Refrigerant leaking online tracking:
 - LOCS Logbook of cooling systems since 2014

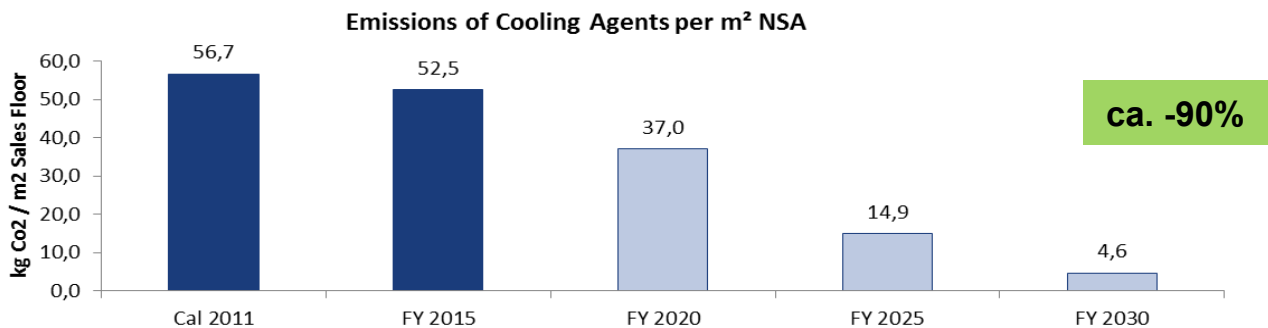

METRO CASH & CARRY

757 stores, HQ in Germany, part of Metro Group

GOOD:

- CO₂ transcritical technology has been rolled out to 51 stores, including one in Romania, five in Italy and one in Spain
- CO₂ cascade systems have been rolled out to 66 stores, including 28 in China, one in Ukraine, 18 in Russia and three in Turkey
- Actively communicating the benefits of using natural refrigerants in media and through production of reports and briefings
- Half of all fridges have doors fitted

BAD:

- Still uses HCFCs in 137 of 757 stores worldwide

EIA GREEN COOLING LEADER



F-GAS EXIT PROGRAM OUTLOOK

- 2017: 1st transcritical system installation in MCC China,
 - NSO Beijing + further roll out plan in FY18
 - 2016 start of GREENSTORE (1) Dongguan with Sub Critical system
 - 2017 Green store (2) Jinan with Sub Critical System
 - 2018 Green store (3) Putuo with Sub Critical system
- 2017: ZEUS-Store MCC Austria St. Pölten with ejector system
 - current 5 transcritical ejector systems in operation in METRO Cash and Carry)
 - further roll out of ejector technology, e.g. MCC Poland
- 2018: Transcritical system in METRO Cash and Carry:
 - 3 transcritical systems in MCC Russia will be constructed in New Store Openings
 - 2 transcritical systems in MCC China will be constructed in existing stores
- 2019/2020: Elimination all HCFC in MCC Russia + MCC China

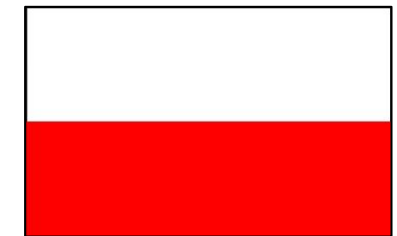
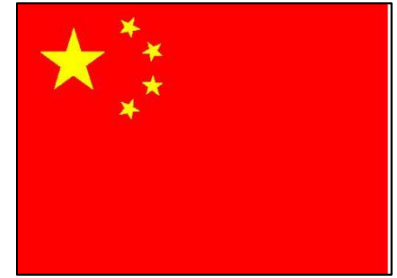



- First wholesale store opened in Shanghai in 1996;
- Cover 58 Chinese cities with 94 stores in operation;
- Employees around 12,000 with 8 million customers
- In the financial year 2016/2017, the sales reached around RMB20.34 billion.
- Multi sales channels to focus on different customer groups: O2O store, Foodservice Distribution, Welfare & Gifting and E-Commerce.
- Set new industry standards in China: the only wholesaler/ retailer with all its stores HACCP certified

MCC CN SUSTAINABILITY DEVELOPMENT TARGET 2030



Business Case for Natural Refrigerants

11-12/04/2018 – Beijing

Energy consumption target with key milestones

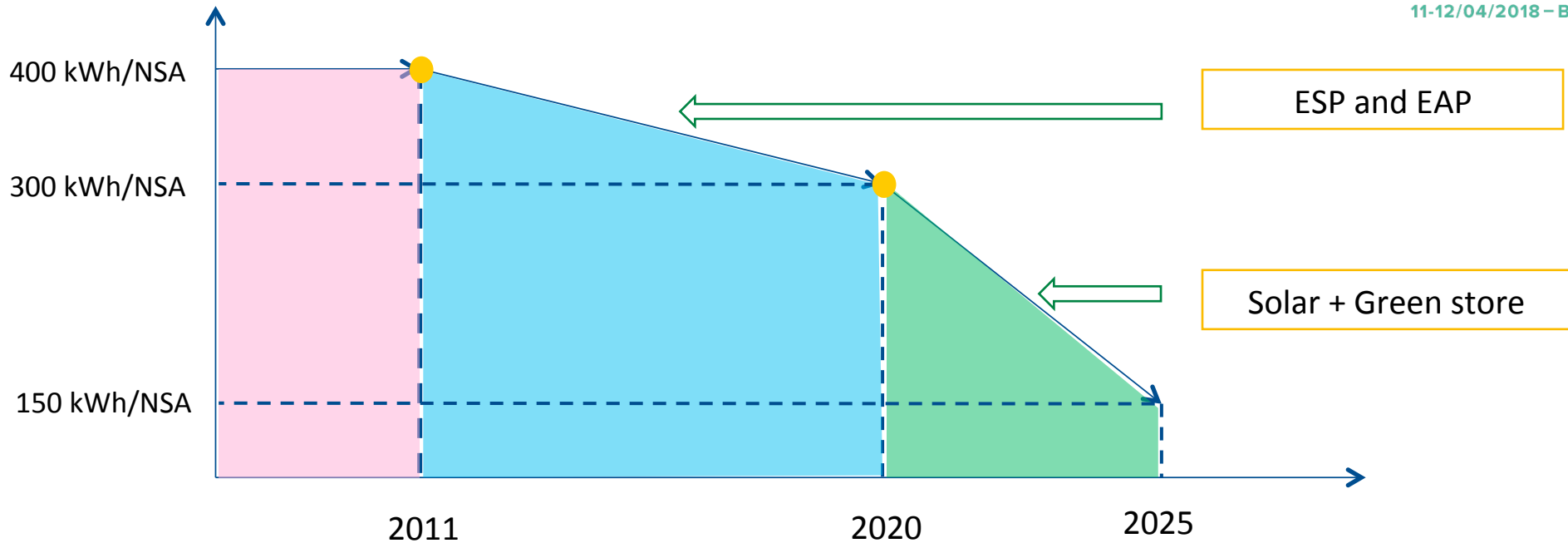

Refrigerant phasing out progress

Refrigerant	2020	2025	2030
R22	Stop producing	Fully quit	
R404A		Stop producing	Fully quit

FEP sub-critical

FEP trans-critical

MCC CN SUSTAINABILITY DEVELOPMENT TARGET 2030

Green group set up
(Investment)



From

To

LFL



NSO + LFL



1. Green store roll out
2. CO2 system from trans-critical to cascade system
3. Solar panel projects

Smart energy management
(Management)



Reduce human power and
equipment investment through
smart management platform



Energy awareness program
(Regular training)



Event/activities based EAP

Regular training/
communication based EAP

MCC CN F-GAS EXIT PROGRAM STATUS

- METRO China FEP progress:
 - 2014 started with 1st sub-critical system in Weifang in NSO;
 - Until 2017, 29 sub-critical system in MCC CN stores;
 - 2017 1st transcritical system in MCC China, NSO Beijing
 - 2018 further roll out transcritical systems in two stores
 - Minus + Plus system with pure CO2 instead H(C)FC
- 2020: Eliminate last HCFC in MCC China stores

GREEN STORE IN CHINA

METRO “Green store” Dongguan 2016

- Remodelling of an existing store
- Full LED + daylight usage with light bands
- Closed cooling furnitures
- CO2 Cascade + heat recovery
- Smart A/C + EMS
- PV top roof + parking canopy + facade (800 KWp)
- Road lamps LED + PV + wind + battery (300 W)
- E-Car-Charger (AC+DC) + rain water usage + waste management system
- appx. 50% energy savings, 60% CO2 savings

METRO “Green store” Jinan and Putuo 2017 & 2018

- NSO + remodeling
- LEED + GBDL + GBL

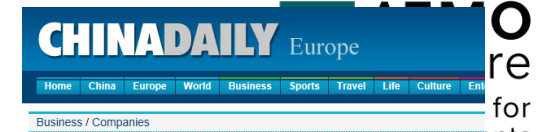

Metro goes green with new Pearl River store

Updated: 2016-09-07 10:28



More for ants
lijing

1ST TRANSCRITICAL SYSTEM IN BEIJING

- Parallel compressing booster system is installed in Metro Beijing Li Shuiqiao store
- Parallel compressing booster system is suitable to be used in north region of China (cold area)
- Mature design and products from Europe
- Sufficient knowledge and using experiences for transferring
- Good energy performance when used in cold area



BEIJING BOOSTER SYSTEM DESIGN

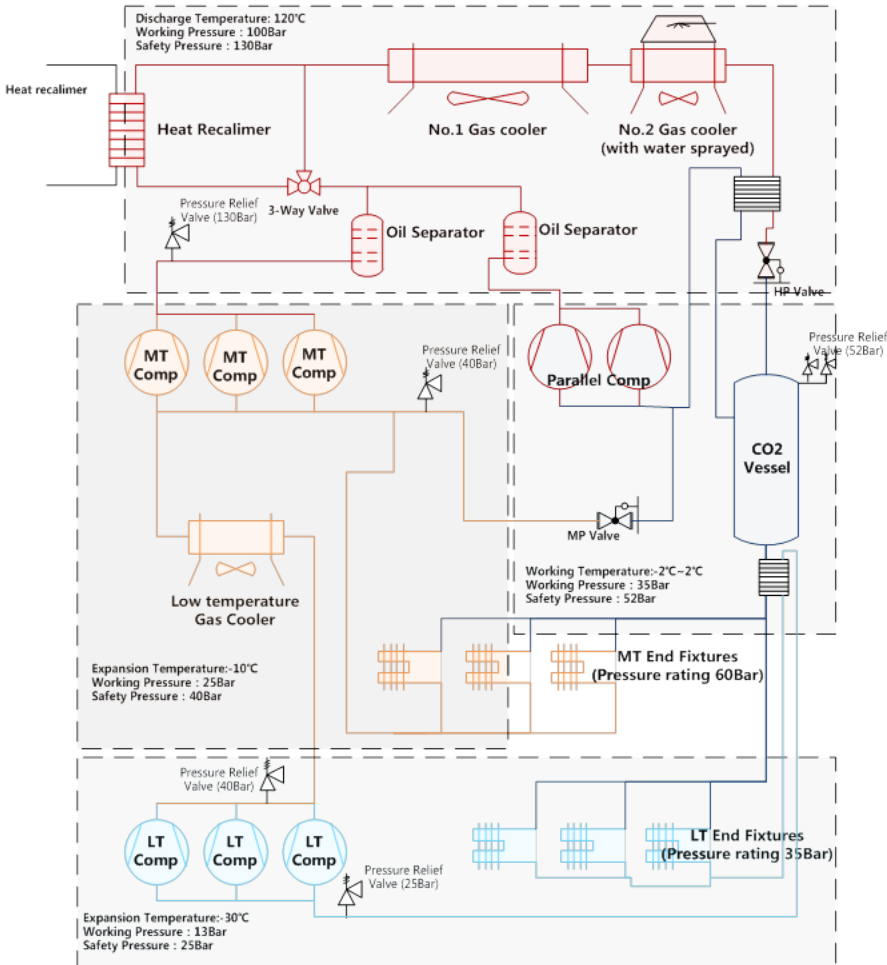

LT + MT

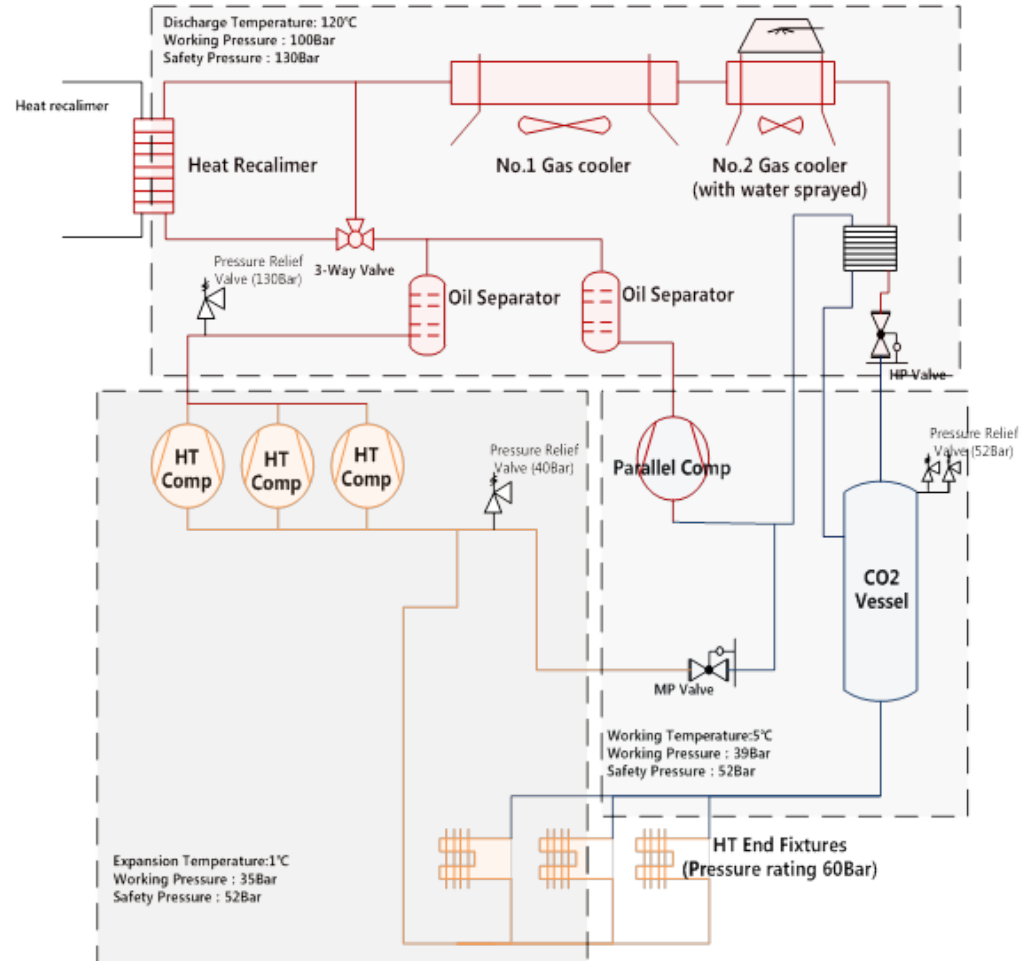

HT

BEIJING BOOSTER SYSTEM OPERATION

- HP side (MT compressor discharge)
 - Working Temperature: 130°C
 - Working Pressure : 100Bar
 - Safety Pressure : 120Bar

- MP side (MT compressor suction)
 - Working Temperature:-10°C~10°C
 - Working Pressure : 30Bar
 - Safety Pressure : 36Bar

- Vessel side (CO2 vessel)
 - Working Temperature:-2°C~2°C
 - Working Pressure : 35Bar
 - Safety Pressure : 45Bar

- LP side (LT compressor suction)
 - Working Temperature:-30°C~-5°C
 - Working Pressure : 13Bar
 - Safety Pressure : 25Bar

BEIJING BOOSTER SYSTEM – RACK OUTLOOK

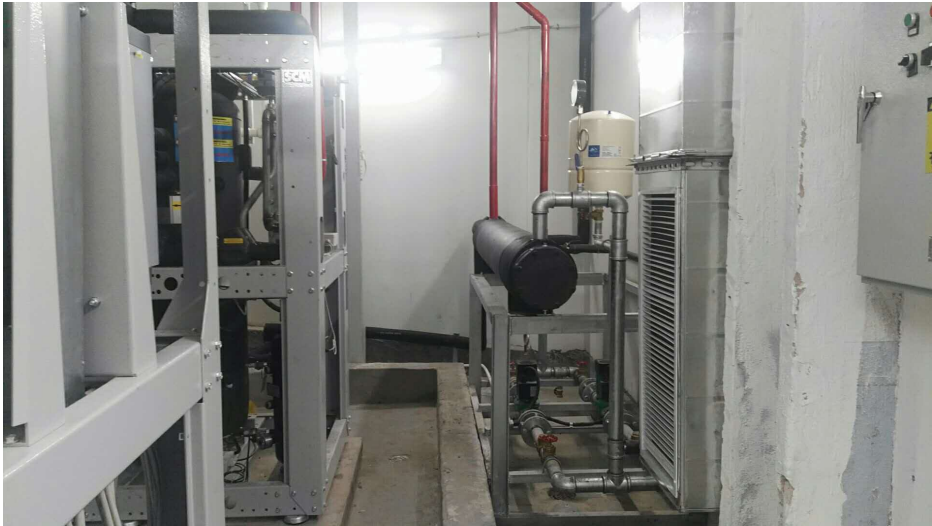

BEIJING BOOSTER SYSTEM – FURNITURE OUTLOOK



TRANSCRITICAL SYSTEM ENERGY PERFORMANCE

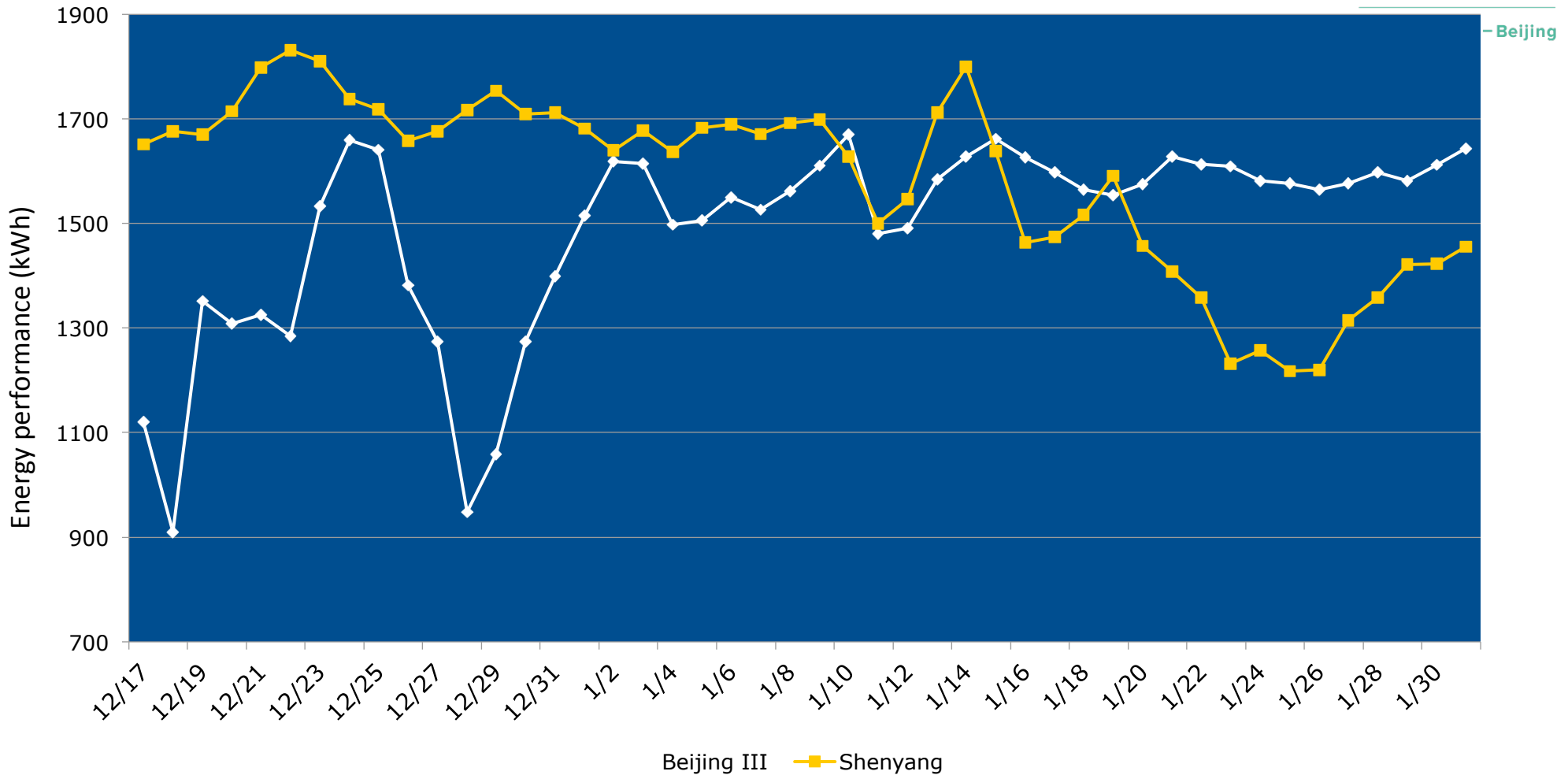

Remark:

Beijing III: Transcritical system

Shenyang: Subcritical system

2018 TRANSCRITICAL SYSTEM ROLL OUT PLAN

- Roll out transcritical system in 2018 to 2 existing stores
- Ejector transcritical system could be used in all China areas (hot + cold area)
- Wide adaptability of the system
- Advanced design with advanced products
- Better energy performance than parallel booster system under different operation environment



REMAINING CHALLENGES IN CHINA

- User training:
 - How to enhance the knowledge and experiences of repair and maintenance personnel
 - How to operate high pressure system by the store engineer
 - How to ease the nerve of normal users regarding high pressure inside the equipment

- Market availability:
 - In-sufficient needs in China markets
 - In-sufficient supplies of knowledge on application in China
 - In-sufficient supplies of skilled personnel, including design, installation and operation

- Geometry of China:
 - Big territory of China and different climates in different areas
 - Different system characteristics on operation and energy performance

- Optimized system design
 - Difficult to find the most optimized design with highest efficiency

THANK YOU!