



Sanden, In Partnership with Nature

Junya (Joe), ICHIKAWA

SANDEN
ENVIRONMENTAL PRODUCTS CORPORATION



Sanden New Structure

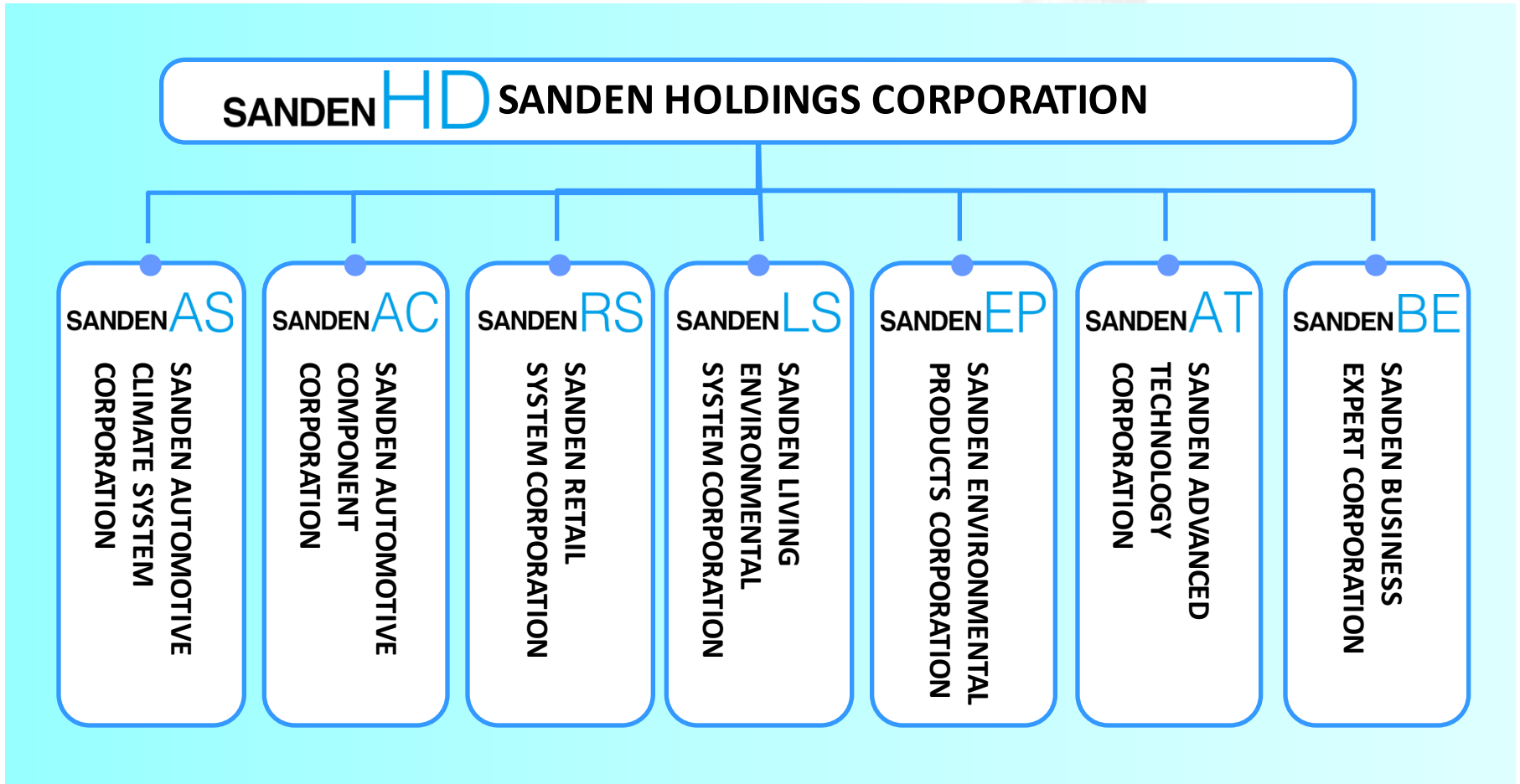

Company Profile

#2

Retail Systems

800 Million USD

Global Share 25%

Vending
Machines



Domestic share 25%

Convenience
Store



Sanden global Network
(53 locations in 23 countries)



Living & Environmental
Systems and Others
90 Million USD

Hot water
heat pump system



Automotive Systems

1,600 Million USD

Global Share 25%

AC System &
Compressor



Corporate Policy

To create corporate values by the environment

We try to grow with the core of the environment
based on the strength we have now



Sanden Focus on CO₂

【Retail Systems】



【Living & Environment】

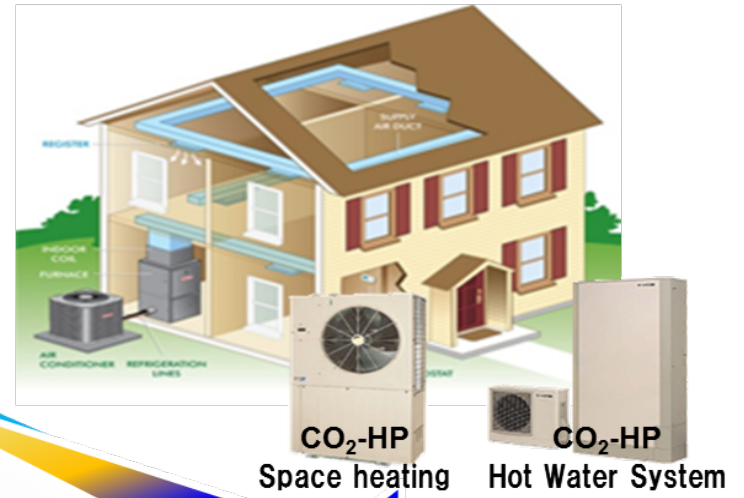

【Automotive Systems】

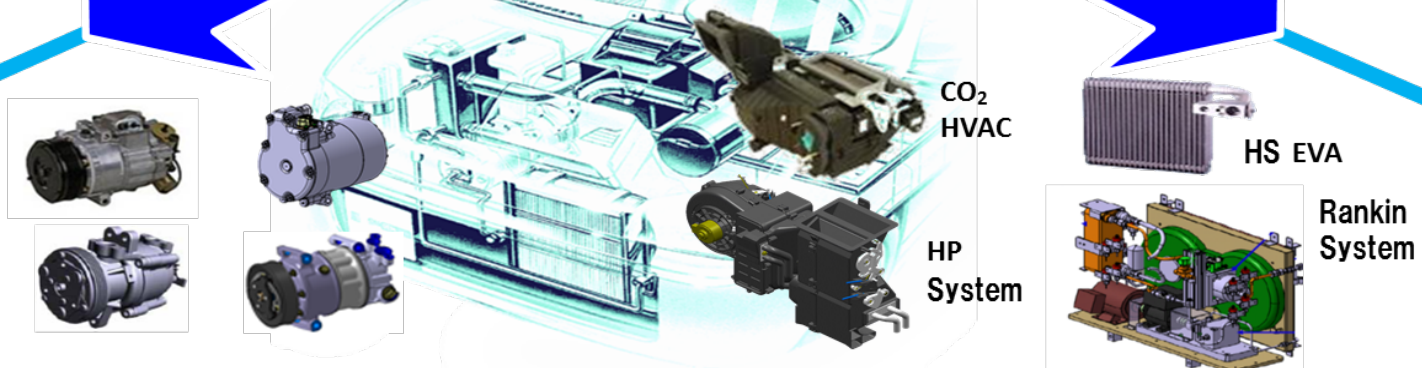

CO₂

Comparison of Energy Consumption

General speaking: The efficiency of CO2 refrigerant is only 67% of R134a ?
We can NOT say the true things with only one aspect.

Advantage of CO2 (VS R134a)

- ☆ Pressure drop in refrigeration circuit is only 1/10
- ☆ Heat transfer efficiency at evaporator is 200%
- ☆ Evaporating latent heat is 125% (at -10°C)

Above 3 points makes big effort for efficiency to refrigeration system.

Market data shows you actual figure.

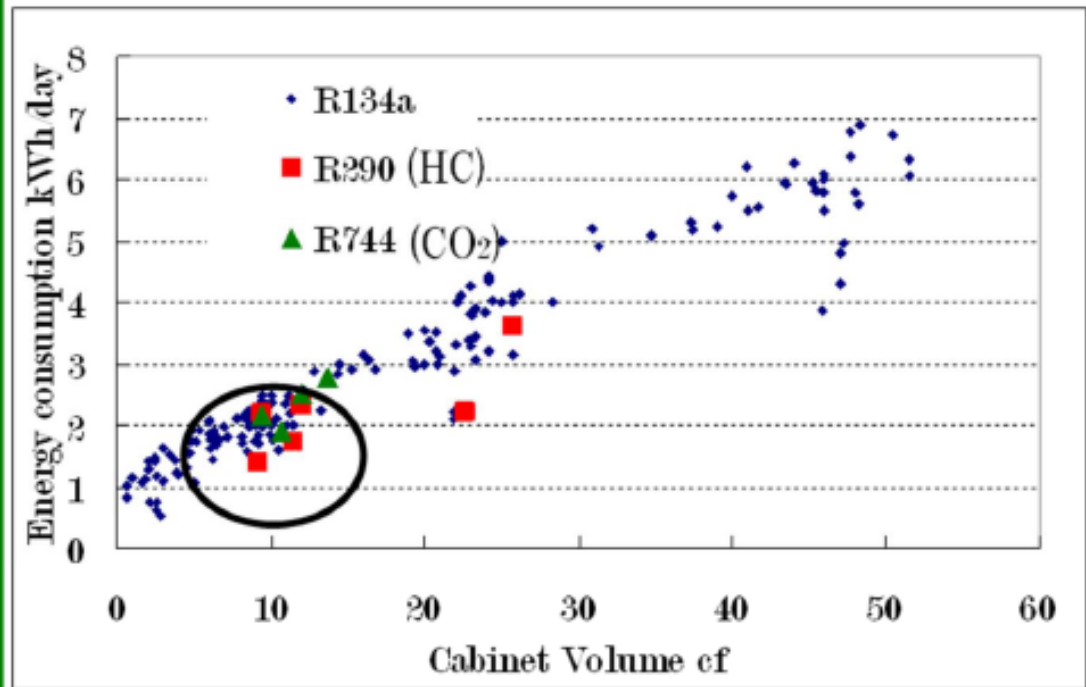

*This data comes from US Energy Star list

Energy Saving with CO₂ Compressor

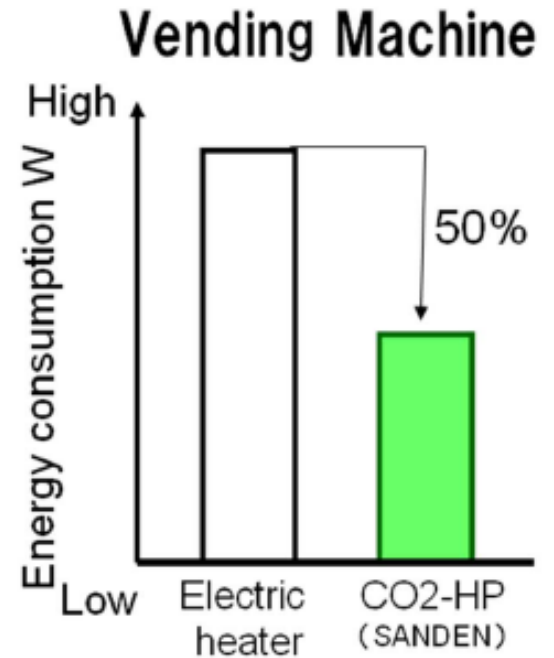
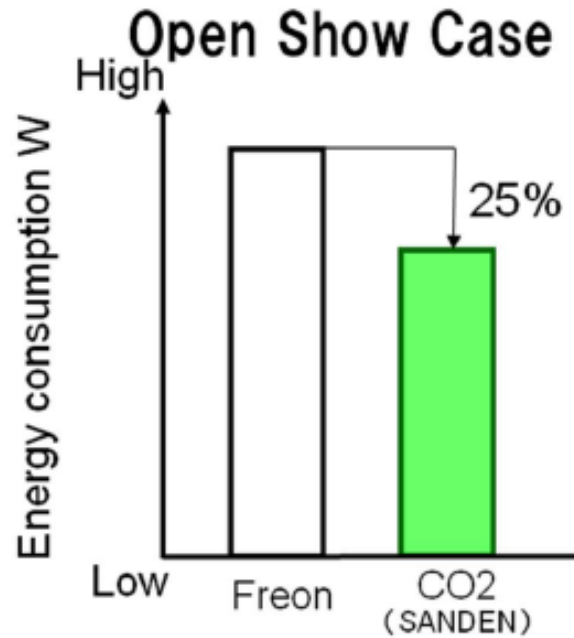
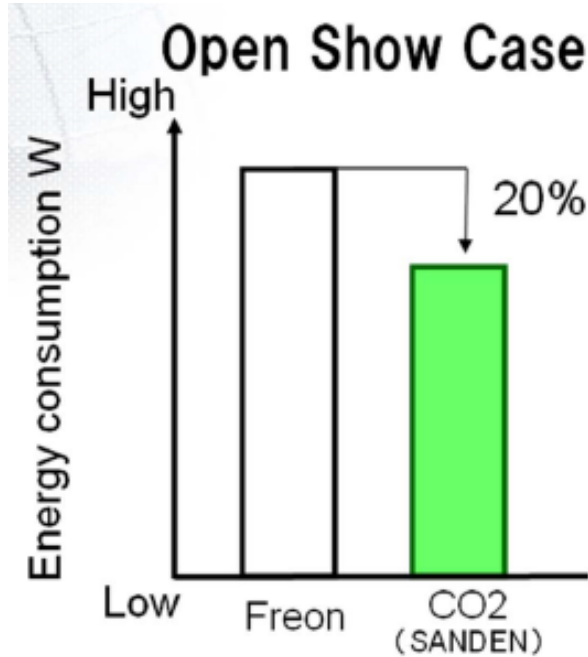

Valuable speed

Energy saving: 20 - 50%

CO₂ Reciprocating Compressor Line Up

#7

| | | Series Model | SRD | SRcF | SRcA | SRcB | SRC | |
|------------------------------|-----------------------|-----------------------------------------------------------|-------------|--------|------------|-------------|--------|--|
| | | Size category | SS | MSc | Sc | Mc | L | |
| 50Hz | Refrigeration [W] | | 200 | 380 | 660 | 960 | 1450 | |
| | (BTU/hr) | | (682) | (1297) | (2252) | (3276) | (4948) | |
| 60Hz | Refrigeration [W] | | 240 | 460 | 790 | 1120 | 1800 | |
| | (BTU/hr) | | (819) | (1570) | (2696) | (3822) | (6142) | |
| Evaporating temp. range [°C] | | For refrigerator temperature application -17.8 ~ +10.8 | | | | | | |
| Dimension | Height/ Diameter [mm] | 169 / f160 | 196 / f163 | | 205 / f172 | 231 / f172 | | |
| Compressor cooling | | <i>Fan cooling</i> | Fan cooling | | | Oil cooling | | |
| Weight | [kg] | 12 | 13 | | 14 | 16.5 | | |

Note1): easuring condition of refrigerating performance,
Suct. press.:2.75MPa(G), Disch. press.:9.07MPa(G)
Suct. gas temp.:24.6°C, Exp. valve inlet temp. :32°C,
Amb. Temp.:35°C



Small Store Solution

#8

① CO₂ Cooling module

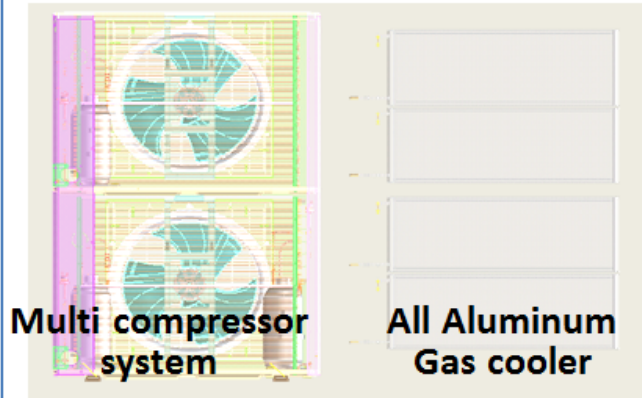

② CO₂ Compressors



- High efficiency
- Low noise & vibration
- High reliability

③ Multi control system

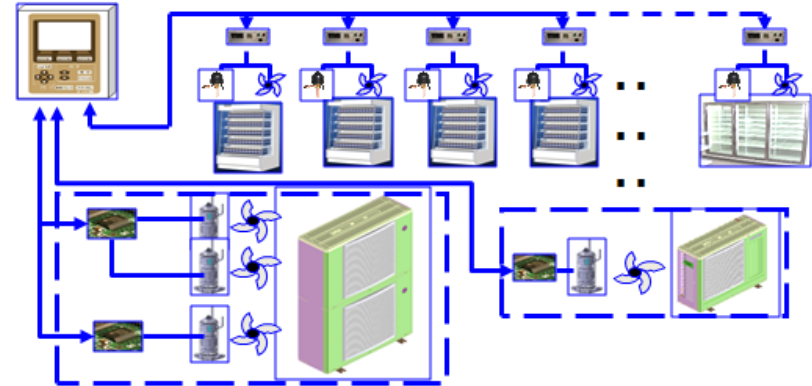

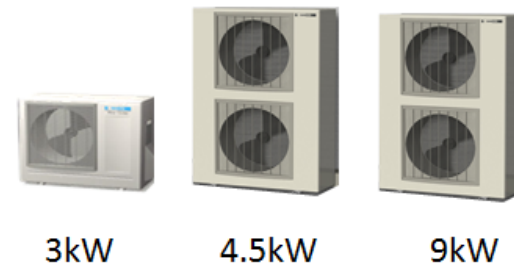

④ Line up

Modules



70 Stores in 2014 - Average real life energy savings of 23%
(vs up-to-date R404a systems)

CO₂ Module Line Up

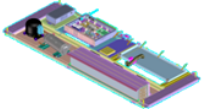
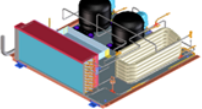
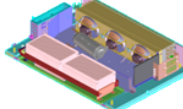
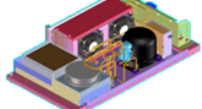
| Model | CDU1 | | CDU2 | CDU3 | CDU4 | CDU5 | CDU6 |
|--------------|-----------------------------------------------------------------------------------|-----------------------------------------------------------------------------------|-----------------------------------------------------------------------------------|-------------------------------------------------------------------------------------------------------|---------------------------------------------------------------------------------------|-------------------------------------------------------------------------------------|-------------------------------------------------------------------------------------|
| Image |  |  |  |  |  |  |  |
| Installation | Remote | Remote | Remote | Plug in Top/ Bottom | Plug in Top/ Bottom | Plug in Top/ Bottom | Plug in Top/ Bottom |
| Compressor | DC variable speed Scroll compressor x3 | DC variable speed Scroll compressor x3 | DC variable speed Scroll compressor x1 | DC variable speed Scroll compressor + DC Variable speed Reciprocating Compressor | DC Variable speed Reciprocating compressor X2 or AC single speed x2 | DC variable speed Scroll compressor | DC Variable speed Reciprocating compressor or AC single speed |

Vision

CO₂ – Globally No1

密閉CO₂コンプレッサーを核に、製品・システム・サービスの
のトータルサプライヤーとなる
Growth to Global Mega-supplier of hermetic CO₂ compressor, system
and service

累積生産台数

Accumulated production volume

0.2M

0.5M

1M

2M



10M

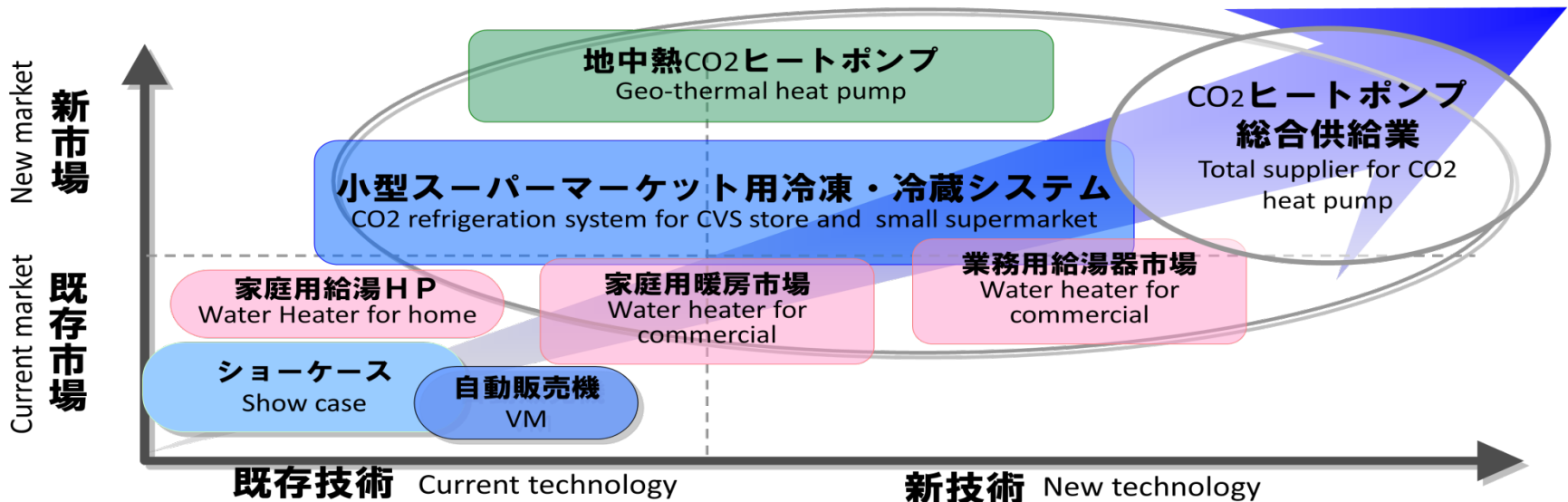



ATMO
sphere
business case
natural refrigerants
25 & 26 June - Atlanta, Georgia

